

TECHNOLOGY FOR
AGRICULTURE AND
BIOGAS PLANTS

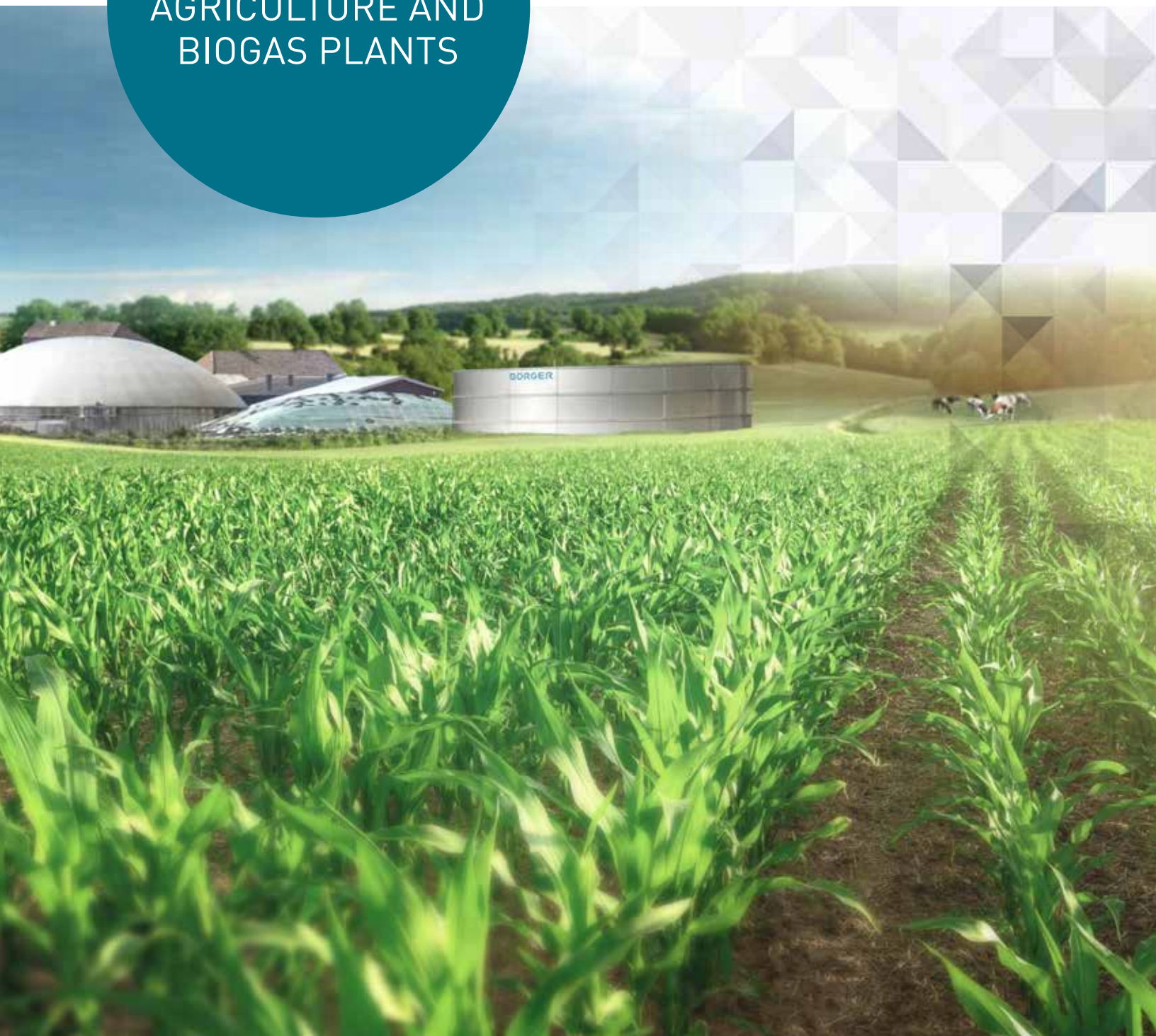

YOU CAN RELY ON THEM: BÖRGER ROTARY LOBE PUMPS



Market leader for elastomer-coated rotary lobe pumps and expert in separation technology. We are represented in more than 65 countries and remain on course for growth. Not only are we a global player but also an independent, family-owned and second generation managed company.

"Constantly making things better" has been our guiding principle right from the start. This is evident by the quality, durability and ease of maintenance of our products. Not only has it shaped our company history since 1975 with continuous new developments and innovations, it also is expressed in the honest and reliable partnership with customers, suppliers and staff.

Our products for agriculture and biogas are customized to the specific demand. Whether pumping and macerating liquid manure, separating solid from liquid parts in digestates and liquid manure, feeding of biomass into a biogas plant or storing liquid manure – our experienced experts know the requirements, recommend suitable products or develop individual solutions for you. Highest quality "Made in Germany".



BÖRGER®

EXCELLENCE – MADE TO LAST

Börger products are designed for trouble free, continuous operation, as we want you to be able to work as effectively as possible. This is the reason why we only offer powerful and durable systems with unbeatable ease of maintenance features.

BÖRGER.

PRODUCT OVERVIEW

AGRICULTURE AND BIOGAS

You can rely on Börger products: We know the requirements of an agricultural company and a biogas plant. Our products have been successfully used in these sectors for more than 40 years.



ROTARY LOBE PUMPS

Börger is a specialist in rotary lobe pumps. We offer solids-resistant rotary lobe pumps with flow rates of 1–7,000 gpm (1–27,000 l/min) and a large selection of equipment and additional parts. The pumps can be used as mobile, stationary or submerged versions.



MACERATING TECHNOLOGY

Börger provides suitable solutions for particle size reduction of solids contained in liquids. Offering the Multicrusher, Multichopper and Rotorrake, we have three different macerators in order to be able to provide an ideal unit for every solid material to be macerated.



SEPARATION TECHNOLOGY

The Börger Bioselect stands for efficient separation technology. Using a purely mechanical process, solids are separated from the liquid phase (such as digestate or liquid manure).



LIQUID FEEDING TECHNOLOGY

The Powerfeed is used for feeding solids into biogas plants. The liquid feeding technology is available in four different versions. Substrates can be introduced via the Powerfeed into the liquid process system, independent of tank elevation and number of tanks.



STAINLESS STEEL TANKS

Börger stainless steel tanks in segmental design with capacities of 7,900 - 1,320,000 gal (30 to 5,000 m³) are very well suited for storing different liquids.



MIXING TECHNOLOGY

In order to homogenize liquids and prevent the formation and deposit of solid layers, the Börger submersible B-MX mixer agitates the storage medium.

BÖRGER ROTARY LOBE PUMPS

ROBUST, RELIABLE AND CUSTOMIZED

Börger rotary lobe pumps have made our company well-known worldwide. The solids handling pumps are powerful, reliable and efficient. Börger pumps convey dirty, sludgy and abrasive media without problems.

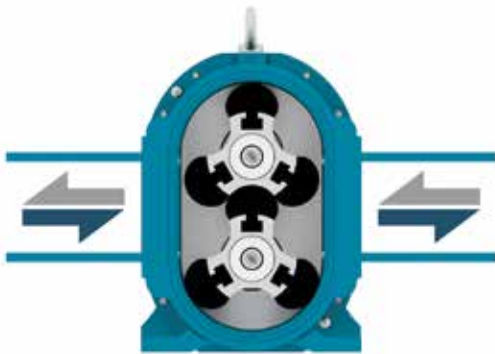

OPERATING PRINCIPLE

Börger rotary lobe pumps are self-priming, valveless, positive displacement pumps. The synchronized rotation of the rotor pair creates a vacuum on the priming side of the pump. This vacuum draws the liquid into the pump chamber. The medium is pumped into the pressure area due to the rotation of the rotors. If the direction of rotation is changed, the flow is reversed.

CONSTRUCTION

- 1 The quick-release cover**
Access to all wetted parts by simply loosening four ring nuts.
- 2 The rotors**
Large selection of high-quality rotors for almost pulsation-free pumping of the medium.
- 3 The casing protection**
The casing liners and casing protection plates protect the pump casing from wear and can be replaced in a matter of minutes.
- 4 The intermediate chamber and shaft seal**
The large-volume quench chamber is oil-filled and ensures the highest degree of safety. The ideal mechanical seal is selected depending on the medium.
- 5 The carrier and timing gear**
The high-quality and maintenance-free carrier and timing gear guarantees a smooth and even operation of the rotors. The result is a long service life of the pump.



ROTARY LOBE PUMPS AT A GLANCE

- + 24 pump sizes with flow rates of 1 – 7,000 gpm (1 – 27,000 l/min)
- + Pumping in slurrp operation
- + Resistant to solids and self-priming
- + Ease of maintenance thanks to MIP
- + Different drive options
- + Short-term dry-run capability

CASE STUDY: TANK FILL SYSTEM

A large agricultural contractor uses a mobile loading system from Börger, transferring manure to their liquid land application equipment. The pump primes the liquid manure through a Börger Rotorrake which macerates the solids. The on-board hydraulic power pack of the mobile transfer system is driven by the PTO of a tractor. There are three hydraulic circuits from the on-board hydraulics which drive the pump, the Rotorrake and the extendable docking arm. The Piadin can be fed from the 52,8 gal (200 l) tank into the liquid flow by means of a dosing pump. In addition, ammonium sulphate solution or UAN can be fed into the liquid flow from an external tank.



HIGH FLEXIBILITY

STATIONARY, MOBILE OR SUBMERGED

STATIONARY OR SUBMERGED

For pump system installations, the structural conditions plant site and required accessories need to be considered. Börger offers complete solutions. In addition to the rotary lobe pump itself, we also manufacture the pump skid components.

The mounting position of the pump / drive combination are selected according to plant requirements. Our rotary lobe pumps can be either driven by an electric motor, a combustion motor, a hydraulic motor, or a PTO shaft of a tractor. The rotary lobe pumps can be used as stationary, mobile or submerged versions due to the flexibility and compact design of the pumps.

MOBILE PUMPS AND TANKER FILL SYSTEM

Börger builds each mobile pump in line with customer's requirements. The pumps can be installed on a three-point hitch frame, on a trailer, on a hand cart or on a tanker truck. Börger supplies special pump systems or mobile unit "turn-key". The design, metal construction and electrical engineering departments meet any challenge.

Börger tanker fill systems are used in many different versions. They are mostly driven by the PTO shaft of a tractor. If media containing solids are pumped, a macerator is recommended.

CONTROL PANEL TECHNOLOGY

Whether rotary lobe pump, macerating unit, separation or feeding technology, optional control panels are adapted to the customer's individual requirements by Börger's electrical engineering department. You can easily control and monitor our agricultural machines via the control cabinet. The control unit coordinates the operation of the devices perfectly in case of more complex installations. For example, the feed pump speed (and the flow rate) is adjusted to the utilization of the Bioselect by the control panel technology. This way, the separator is always operated at optimal capacity. Our electrical engineering department can directly access your control panel technology by means of an optional remote maintenance module and can directly take measures if you need assistance or have a question.



**STATIONARY
OR SUBMERGED**



**MOBILE PUMPS AND
TANKER FILL SYSTEMS**



**CONTROL PANEL
TECHNOLOGY**

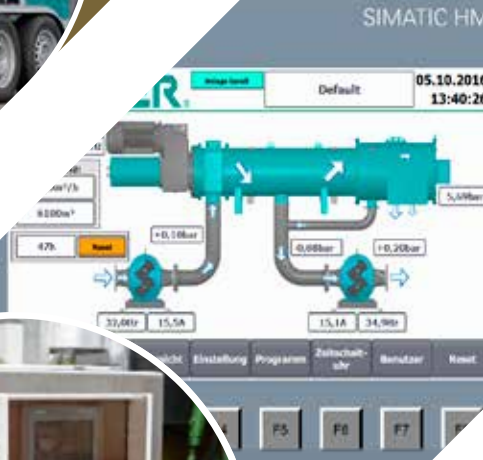

MAINTENANCE IN PLACE (MIP)

SIMPLE. EASE OF MAINTENANCE.



Börger products are designed for trouble-free, continuous operation and incorporate unbeatable ease of maintenance features. All components are extremely resilient and durable. Instead of expensive maintenance contracts, Börger offers MIP (Maintenance in Place). Control maintenance and repair procedures yourself. Product wetted parts can be replaced at the installation site without the need to remove piping and the drive system. Easily and quickly.



ROTOR AND CASING PROTECTION

Just the removable lobe tips of the patented rotor "Unique" have to be replaced in case of wear. Our Premium profile rotor has been especially designed for the biogas sector and offers long service life in case of pumped media containing fibers. The casing liners and casing protection plates protect the pump casing and can be replaced through the quick-release cover in case of wear just as the single-acting mechanical seal. This way, the pump is like in a new condition within a few minutes.



SEVERAL PUMP SIZES

With the wide spectrum of eight series with 24 pump sizes (flow rates of 1 – 7,000 gpm), a large selection of equipment and additional parts, Börger is able to build rotary lobe pumps which are perfectly suited to every single application.

Börger rotary lobe pump overview

Series	Flow rate in gpm (l/min)		Max. pressure in psi (bar)
	Min.	Max.	
BLUEline AN	0.1 (0.5)	155 (580)	115 (8)
ONIXline BJ	0.2 (0.9)	295 (1,120)	230 (16)
BLUEline PL	0.2 (0.9)	665 (2,520)	175 (12)
ONIXline BL	0.5 (1.9)	590 (2,240)	230 (16)
BLUEline CL	0.7 (2.6)	825 (3,120)	175 (12)
BLUEline FL	1.5 (5.7)	1,805 (6,840)	175 (12)
BLUEline EL	2.7 (10.3)	4,900 (18,540)	145 (10)
BLUEline XL	4.6 (17.6)	7,040 (26,650)	145 (10)

FOR SIMPLE TRANSFER OPERATIONS EASY SOLUTION

Submersible centrifugal pumps can be used for simple transfer operations with short distances and minor height differences.

SUBMERSIBLE CENTRIFUGAL PUMPS

Submersible centrifugal pumps can be used for conveying fluids with low solids content. The submersible pump is lowered into the liquid to be pumped and uses the feed from below. The pump is driven by a submersible motor.

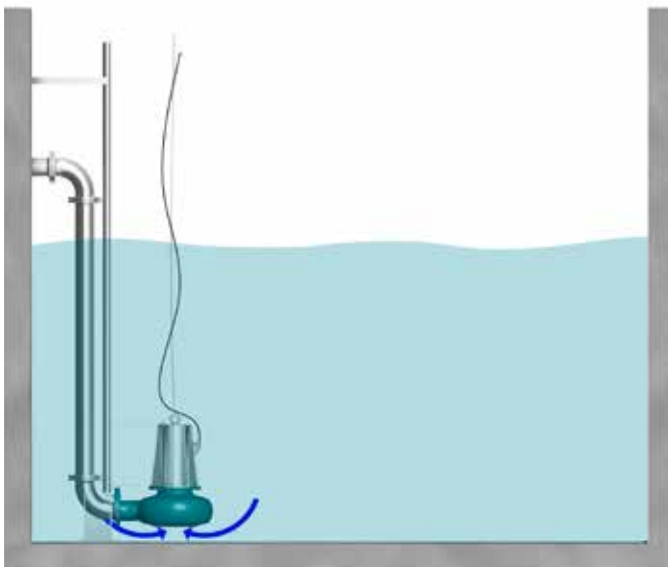

SUBMERSIBLE CHOPPER MIX PUMPS

The pump wheel of the submersible cutting pump is equipped with cutting edges. This way, fibers are macerated during the pumping process. By simply moving a valve, the submersible chopper mix pump can be used for transfer operations or for circulation by means of an agitating nozzle.

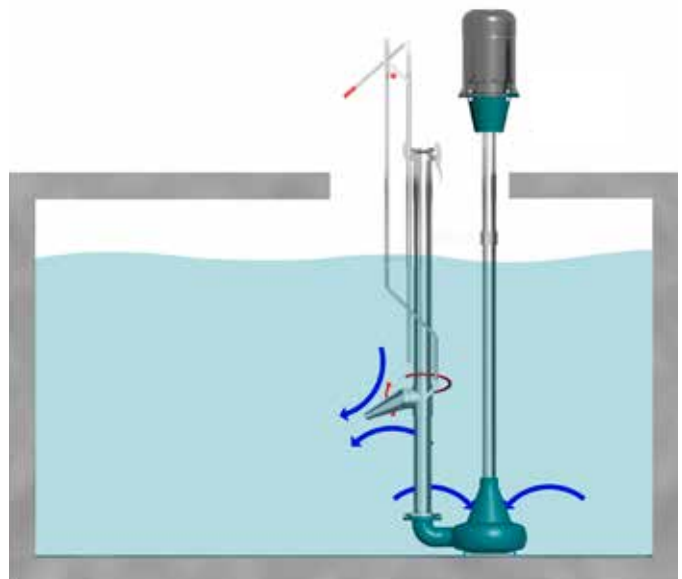

MACERATING TECHNOLOGY

COMPACT AND POWERFUL

By offering three different macerators, we are able to provide the ideal unit for every macerating task. You can select from a perforated disk macerator, a dual-shaft grinder or a one-shaft macerator.

THREE MACERATING TECHNIQUES

The Börger Multichopper is a macerator with a central, perforated disk and high-performance blades for size reduction of solids contained in liquids.

The Multicrusher is a universal and powerful dual-shaft grinder which is based on the basic design of the proven Börger rotary lobe pump. The two shafts are equipped with blades and spacers instead of rotors.

The Rotorrake is a robust, single-shaft coarse macerator which tackles macerating tasks where others have failed – for macerating very coarse solids and rags. Each of our macerators is available in different sizes.

Börger macerator overview

Macerator	Max. capacity in gpm (l/min)	Max. pressure in psi (bar)
Multicrusher	1150 (4,300)	175 (12)
Multichopper	1760 (6,600)	75 (5)
Rotorrake	2380 (9,000)	75 (5)

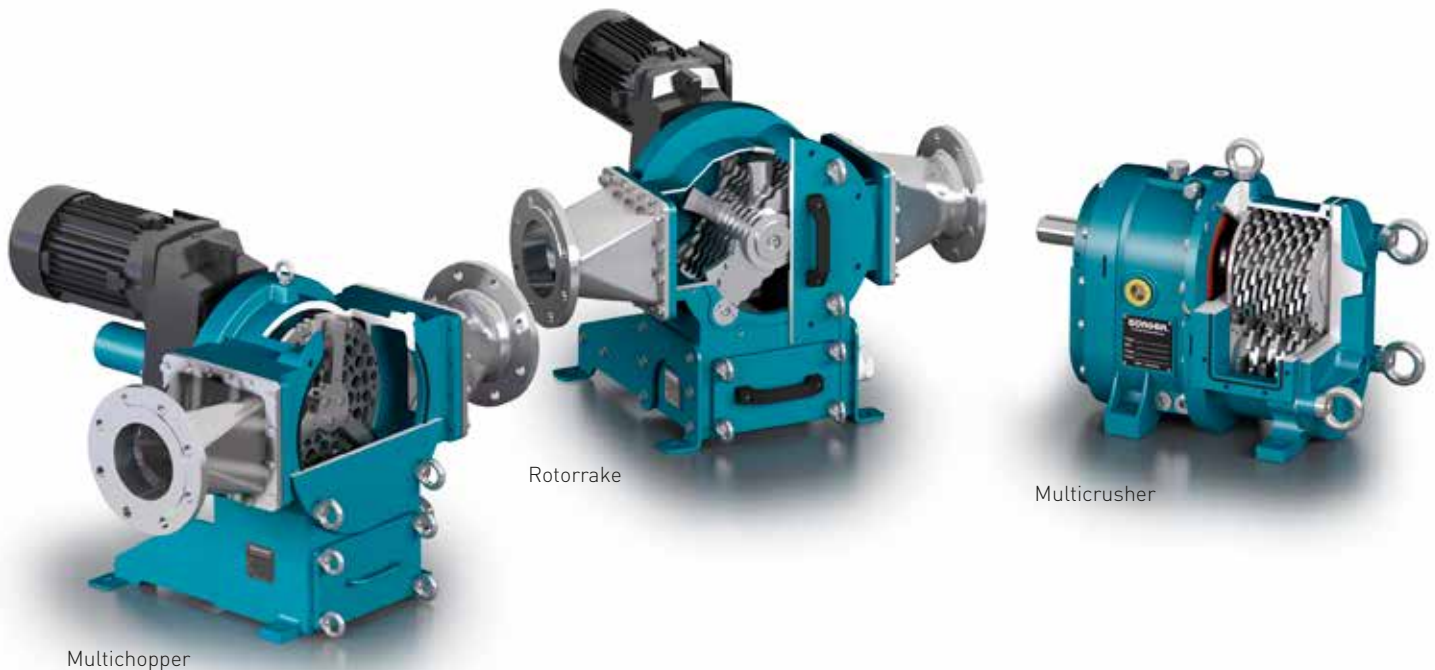

MACERATOR AT A GLANCE

- + Excellent cutting result
- + Optional debris separator / collector
 - + Low life-cycle costs
 - + Can be supplied in stainless steel
 - + Energy efficient

CASE STUDY: SECONDARY MACERATION IN A BIOGAS PLANT

A Börger Multichopper is used for secondary maceration of fermentation substrate in a biogas plant in Germany. The operator of the plant uses a screw auger to feed the biomass into the fermenter. In order to achieve higher gas yield and remove impurities from the fermenter, the fermentation substrate is conveyed through the Multichopper by means of a Börger rotary lobe pump. All debris is separated in the foreign body separator of the perforated disk macerator. The mixing needs in the tank have been reduced and the gas yield increased by using the macerator.



STAINLESS STEEL TANKS

DURABLE AND LASTING VALUE

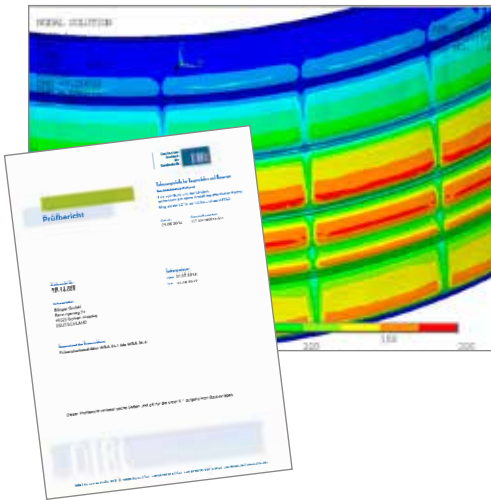

Börger stainless steel tanks available in different material grades are suitable for storing any liquid.

Capacities between 8000 to 1,320,000 gal (30 to 5,000 m³), various accessories and roof constructions allow a customized, customer centered solution. The tanks can be installed quickly and the storage size can be increased without problems due to the segmented tank design. The segments are easy to transport (compact) and can be installed in existing premises, if necessary. The Börger standard tank is static-tested and certified.

BÖRGER TANKS OVERVIEW

Type	Cyl. height * Ø feet (m)	*feet (m) Area sq ft (m ²)	1 4.92 (1.50) in gal (m ³)	2 9.84 (3.00)	3 14.76 (4.50)	4 19.22 (6.00)	5 24.61 (7.50)	6 29.53 (9.00)	7 34.45 (10.50)	8 39.37 (12.00)
04	12.17 (3.71)	118.40 (11)		8,567 (32)	12,851 (49)	17,134 (65)	21,418 (81)	25,702 (97)	29,984 (114)	34,269 (130)
05	15.19 (4.63)	182.98 (17)		13,343 (51)	20,014 (76)	26,686 (101)	33,357 (126)	40,029 (152)	46,701 (177)	53,372 (202)
06	18.24 (5.56)	258.33 (24)	9,620 (36)	19,241 (73)	28,862 (109)	38,483 (146)	48,104 (182)	57,725 (219)	67,346 (255)	76,967 (291)
07	21.26 (6.48)	355.20 (33)	13,068 (49)	26,136 (99)	39,204 (148)	52,273 (198)	65,341 (247)	78,409 (297)	91,477 (346)	104,546 (396)
08	24.31 (7.41)	462.84 (43)	17,088 (65)	34,177 (129)	51,265 (194)	68,354 (259)	85,442 (323)	102,531 (388)	119,619 (453)	136,708 (517)
09	27.36 (8.34)	592.01 (55)	21,647 (82)	43,294 (164)	64,941 (246)	86,588 (328)	108,235 (410)	129,882 (492)	151,529 (574)	173,176 (656)
10	30.38 (9.26)	721.18 (67)	26,686 (101)	53,372 (202)	80,059 (303)	106,745 (404)	133,431 (505)	160,118 (606)	186,804 (707)	213,491 (808)
11	33.43 (10.19)	882.63 (82)	32,315 (122)	64,631 (245)	96,947 (367)	129,263 (489)	161,579 (612)	193,895 (734)	226,211 (856)	258,527 (979)
12	36.48 (11.12)	1044.09 (97)	38,483 (146)	76,967 (291)	115,451 (437)	153,935 (583)	192,418 (728)	230,902 (874)	269,386 (1020)	307,870 (1165)
13	39.50 (12.04)	1227.08 (114)	45,114 (171)	90,229 (342)	135,344 (512)	180,459 (683)	225,574 (854)	270,689 (1025)	315,804 (1195)	
14	42.55 (12.97)	1420.83 (132)	52,353 (198)	104,707 (396)	157,061 (595)	209,415 (793)	261,768 (991)	314,122 (1189)	366,476 (1387)	
15	45.57 (13.89)	1636.11 (152)	60,044 (227)	120,088 (455)	180,133 (682)	240,177 (909)	300,221 (1136)	360,266 (1364)		
16	48.62 (14.82)	1862.15 (173)	68,354 (259)	136,708 (517)	205,062 (776)	273,416 (1035)	341,770 (1294)	410,124 (1552)		
17	51.67 (15.75)	2098.96 (195)	77,202 (292)	154,404 (584)	231,606 (877)	308,808 (1169)	386,010 (1461)	463,212 (1753)		
18	54.69 (16.67)	2346.53 (218)	86,484 (327)	172,969 (655)	259,454 (982)	345,938 (1310)	432,423 (1637)	518,908 (1964)		
19	57.74 (17.6)	2615.62 (243)	96,403 (365)	192,807 (730)	289,210 (1095)	385,614 (1460)	482,018 (1825)	578,421 (2190)		
20	60.79 (18.53)	2906.25 (270)	106,860 (405)	213,721 (809)	320,582 (1214)	427,443 (1618)	534,304 (2023)	641,165 (2427)		
21	63.81 (19.45)	3196.87 (297)	117,735 (446)	235,470 (891)	353,206 (1337)	470,941 (1783)	588,677 (2228)			
22	66.86 (20.38)	3509.03 (326)	129,263 (489)	258,527 (979)	387,790 (1468)	517,054 (1957)	646,318 (2447)			
23	69.88 (21.3)	3831.94 (356)	141,197 (534)	282,395 (1069)	423,592 (1603)	564,790 (2138)	705,987 (2672)			
24	72.93 (22.23)	4176.39 (388)	153,796 (582)	307,593 (1164)	461,389 (1747)	615,186 (2329)	768,983 (2911)			
25	75.98 (23.16)	4531.60 (421)	166,934 (632)	333,868 (1264)	500,802 (1896)	667,736 (2528)	834,670 (3160)			
26	79.00 (24.08)	4908.33 (456)	180,459 (683)	360,919 (1366)	541,379 (2049)	721,839 (2732)	902,299 (3416)			
27	82.05 (25.01)	5285.07 (491)	194,668 (737)	389,336 (1474)	584,004 (2211)	778,673 (2948)	973,341 (3684)			
28	85.10 (25.94)	5683.33 (528)	209,415 (793)	418,830 (1585)	628,245 (2378)	837,660 (3171)	1047,075 (3964)			
29	88.12 (26.86)	6103.13 (567)	224,532 (850)	449,065 (1700)	673,598 (2550)	898,131 (3400)	1122,664 (4250)			
30	91.17 (27.79)	6522.92 (606)	240,350 (910)	480,700 (1820)	721,051 (2729)	961,401 (3639)	1201,752 (4549)			
31	94.19 (28.71)	6975 (648)	256,527 (971)	513,055 (1942)	769,583 (2913)	1026,110 (3884)	1282,638 (4855)			
32	97.24 (29.64)	7427.09 (690)	273,416 (1035)	546,832 (2070)	820,248 (3105)	1093,665 (4140)	1367,081 (5175)			
33	100.30 (30.57)	7900.70 (734)	290,843 (1101)	581,686 (2202)	872,529 (3303)	1163,372 (4404)				
34	103.28 (31.48)	8385.07 (779)	308,416 (1167)	616,832 (2335)	925,249 (3502)	1233,665 (4670)				

*Special and intermediate sizes possible

APPLICATION OPTIONS

Börger stainless steel tanks are versatile, e.g.:

- Liquid manure
- Animal Feed
- Liquid fertilizer
- Beet Storage
- Fermenter
- Wastewater and sludge

STAINLESS STEEL TANK AT A GLANCE

- + Capacity of 8,000 to 1,320,000 gal
(30 to 5,000 m³)
- + Different roof constructions possible
- + Maintenance-free and lasting value
- + Can be increased and disassembled
- + Versatile



B-MX SUBMERSIBLE MIXER

MORE EFFECTIVE AGITATION



The B-MX submersible mixer ensures that liquid media with solids are effectively agitated.

OPERATING PRINCIPLE

The design without edges of the device allows liquid to flow to the displacement blades without creating turbulence. This guarantees high efficiency. The high-precision casing and all wetted parts are made of solid stainless steel.

CONSTRUCTION AND FUNCTION

- 1 B-MX**
The submersible mixer is connected to the guide pipe by means of the guide carriage.
- 2 Guide carriage and guide pipe**
The guide pipe guides the mixer.
- 3 Container wall**
Attaching the mixer to the container wall is not necessary.
- 4 Working platform**
The adjustment unit can be accessed via the working platform. In addition, it can be used to look into the tank.
- 5 Adjustment unit**
The adjustment unit can be used to change the height of the mixer and the lateral alignment. In addition, the adjustment unit is used for fixing the guide pipe.



B-MX AT A GLANCE

- + Different sizes
- + Completely made of stainless steel
- + Good flow to the propellers
- + Cable inlet at the protected rear of the mixer
- + High efficiency

Börger B-MX overview

B-MX	Output in HP (kW)	Output in gpm (m³/h)	Rotational speed in rpm	Weight in lbs (kg)
B-MX 9	12 (9)	16,640 (3780)	342	265 (120)
B-MX 13	18 (13)	22,100 (5020)	342	365 (165)
B-MX 18	25 (18)	30,200 (6860)	342	410 (185)
B-MX 22	30 (22)	38,040 (8640)	342	551 (250)

GOOD FLOW PROPERTIES

The slim design of the B-MX and the geometry of the agitator blades have been optimized with the latest flow simulation software to ensure highest efficiency.

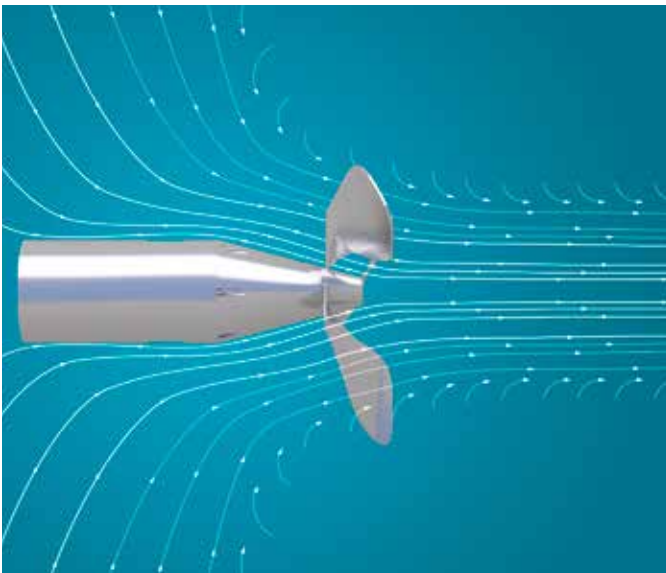

CIRCULATION MIXER

The B-MX submersible mixer is also available with a jet ring for circulation channel applications for increased mixing efficiency.



PERFECT SEPARATION RESULT BÖRGER BIOSELECT

The Börger Bioselect stands for efficient separation technology. Using a purely mechanical process, liquid parts are separated from solid parts in the medium (such as digestate or liquid manure).

OPERATING PRINCIPLE

The media to be separated find their way through the inlet opening **(1)** into the vessel-like Bioselect. The outer cylinder is separated from the auger **(3)** by a roundly sealed wedge wire screen **(2)**. The auger has a frictional connection to the drive. The imported liquid flows into the screen area next to the drive. The liquid flows through the wedge wire screen **(2)** into the outer vessel area. The liquid drains through the liquid outlet **(4)**.

The solid contents remain on the screen surface. They are removed and conveyed into the press channel **(5)** by the rotating auger **(3)**. Powerful subsequent dewatering takes place in the press channel **(5)**. The rotating auger has a Multi Disc **(6)** (sealing disk), which can be shifted in axial direction, at the non-drive end. The adjusting unit **(7)** presses the Multi Disc against the auger and the compressed thick matter plug. When the thrust force of the plug is greater than the spring force of the Easy Shift unit, a slot for discharging is created by axial movement. A scraper is used to loosen and expel the solids.

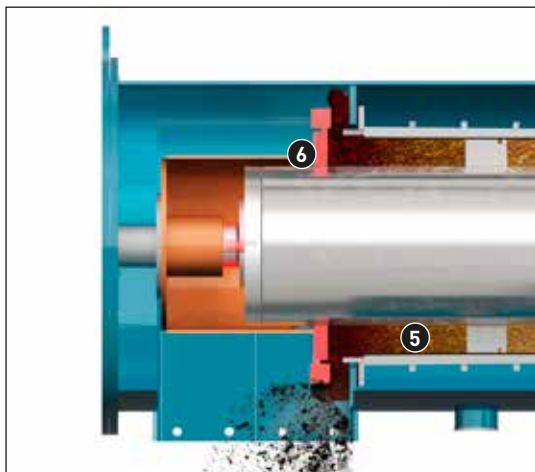
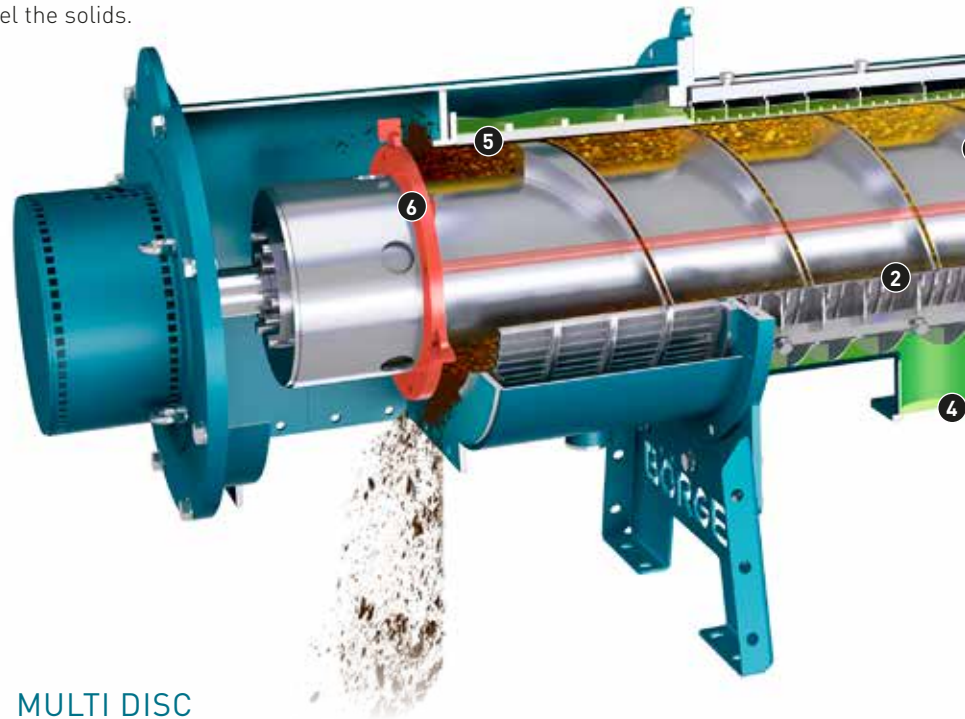

MULTI DISC

Liquid penetration is impossible due to the Multi Disc technology **(6)**, whether the desired DS content is at 15 or 38%. The Multi Disc **(6)** seals the press channel **(5)** as long as the required drying stage of the thick matter plug is achieved. This is when the slot for discharging opens and the solid phase is loosened and expelled – **penetration-proof technology**.

WHY SEPARATION?

- + Management of storage capacity during non-land application periods
- + Separated solids are energy supplier and earthy fertilizers
- + Solid phase as bedding material
- + Liquid filtrate is a fast-acting fertilizer rapidly available to the plants
- + No damage to the plants as the liquid phase directly enters the soil

EASY SHIFT TECHNOLOGY

The DS content can be varied continuously by means of the Easy Shift **(7)** unit. Alternatively, the DS content can be adapted fully automatically (pneumatically) by means of a control unit.

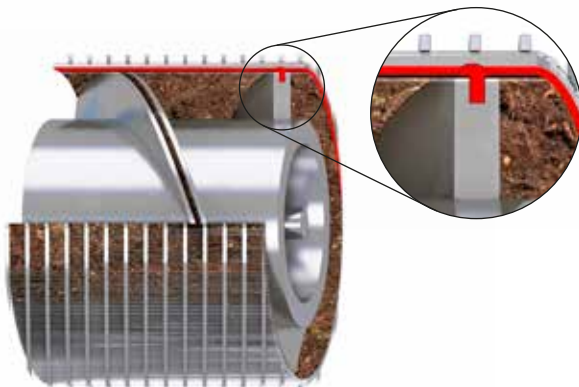
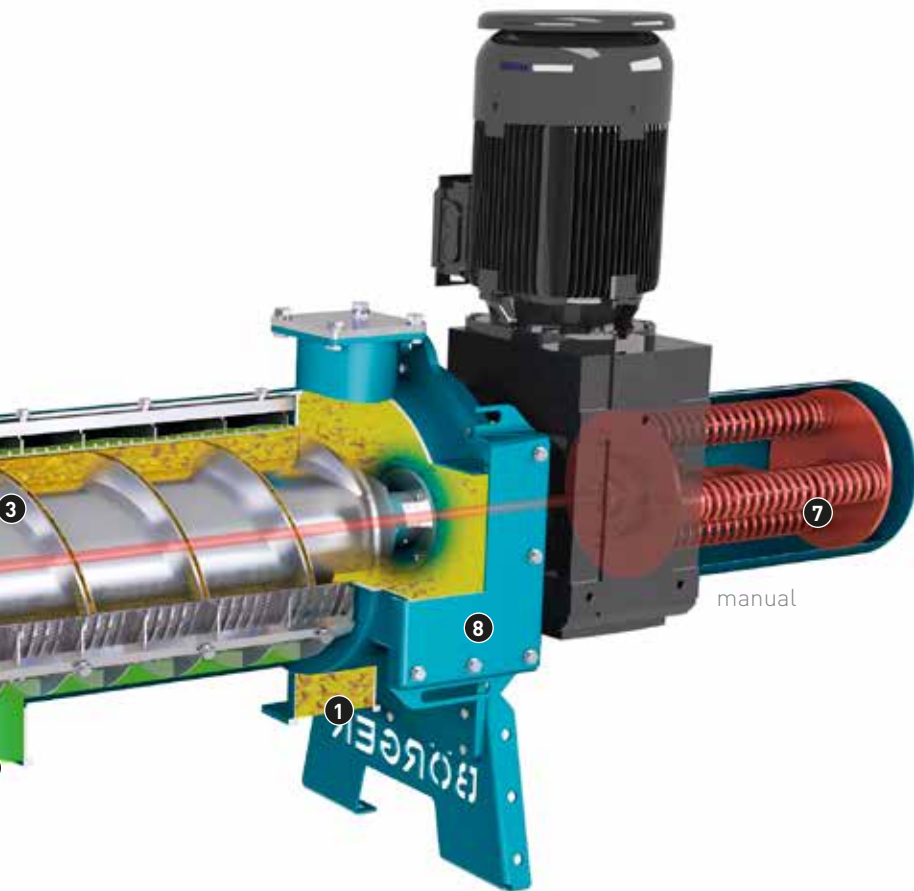

AUGER WITH PROFILE GROOVE

Fibers are caught in the profile groove of the auger **(3)**. The fibers function as a sealing brush. Metallic rubbing between the auger and the wedge wire screen **(2)** is avoided by the brush. This unique technology increases the service life of the wedge wire screen **(2)** and auger many times over. In addition, the brushing surface cleans the wedge wire screen very thoroughly. Additional cleaning by the operator is not necessary.

SOPHISTICATED TECHNOLOGY LEAKPROOF SEPARATION

The Bioselect is available in four sizes with maximum capacities of between 132 and 660 gal/min (30 and 150 m³/h). The separator achieves infinitely variable dry solids contents (DS content) between 15 and 38 percent so that the solid phase can be used as thickened solid, stackable mass or bedding for livestock farms.

READY-TO-CONNECT UNIT "FROM A SINGLE SOURCE"

Börger mostly supplies the Bioselect as a complete unit ready for operation. The separator is fed by means of a Börger rotary lobe pump. The separator can be operated very easily by means of the Börger control unit. The control unit coordinates the operation of the feed pump and Bioselect perfectly. This way, the separator is always operated at optimal capacity and achieves the best possible results.

INSTALLATION OPTIONS

Whether attached to a simple wall bracket, installed on a movable frame with an upstream macerator or as a mobile version with a conveyor belt – the application options of the Bioselect are versatile.

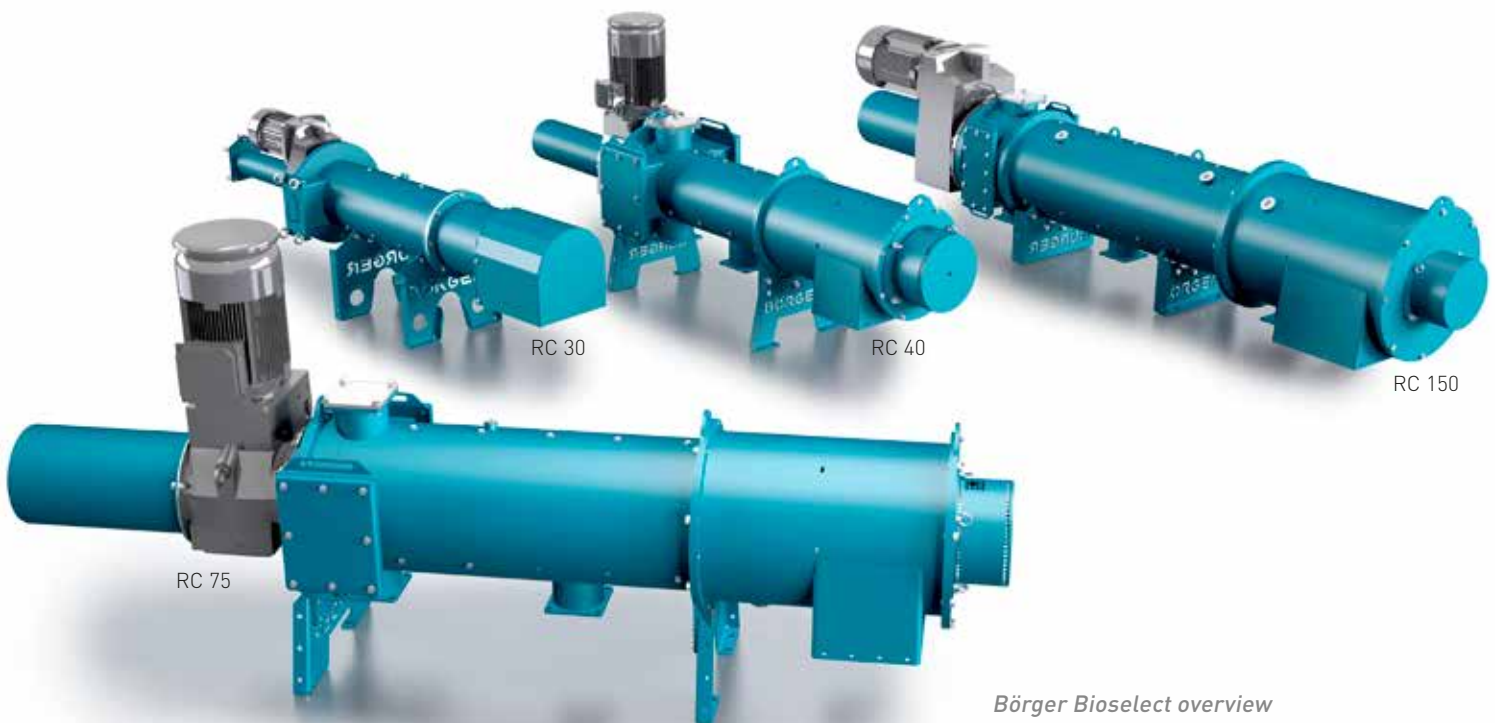

Börger Bioselect overview

Model	Capacity in gal/min (m ³ /h)
Bioselect RC 30	Up to 132 (30)
Bioselect RC 40	Up to 176 (40)
Bioselect RC 75	Up to 330 (75)
Bioselect RC 150	Up to 660 (150)



BIOSELECT AT A GLANCE

- + Double side auger bearing assembly resulting in increased longevity and higher throughput with equal energy consumption
- + Solid phase infinitely variable up to a solid content of 15 to 38 %
- + No risk of penetration – the Multi Disc is always leakproof even with low DS contents
- + Four sizes with capacities of up to 660 gal/min (150 m³/h) for each unit
- + Perfect adaptation due to wedge wire screen with different slot opening widths

CASE STUDY: BIOSELECT FOR MANAGING STORAGE CAPACITY

In order to manage storage capacity for liquid manure during non-land applications periods, a dairy farm uses a Börger Bioselect. The farmer opted for a Bioselect because he can determine the DS content in the separated thick matter flexibly with our technology. The farmer uses a part of the separated solid phase as bedding for his dairy cows. For this purpose, he sets the DS content to 32 %. In addition, he cooperates with a neighboring biogas plant which takes the solid phase free of charge. For the biogas plant, the farmer sets the DS content to 20%.



POWERFEED

BEST LIQUID FEEDING TECHNOLOGY

The Powerfeed is used for feeding solids into biogas plants. The Powerfeed technology is installed at an appropriate position in the pressure pipe system. The Börger dosing technology conveys the biomass into the flow pipeline in the fully enclosed system.

The Powerfeed is available in two sizes and four different versions. This way, the ideal technology can be offered for each plant. The Powerfeed is fed through the feed hopper in the basic version. The Powerfeed connect is fed from the side. The Powerfeed duo is a combination of a stainless steel storage container (capacity of 1320 to 3962 gal).

NEW POWERFEED TWIN

The new Powerfeed twin with its two powerful auger shafts has been developed for special applications – feeding of large quantities of widely varying biomass.

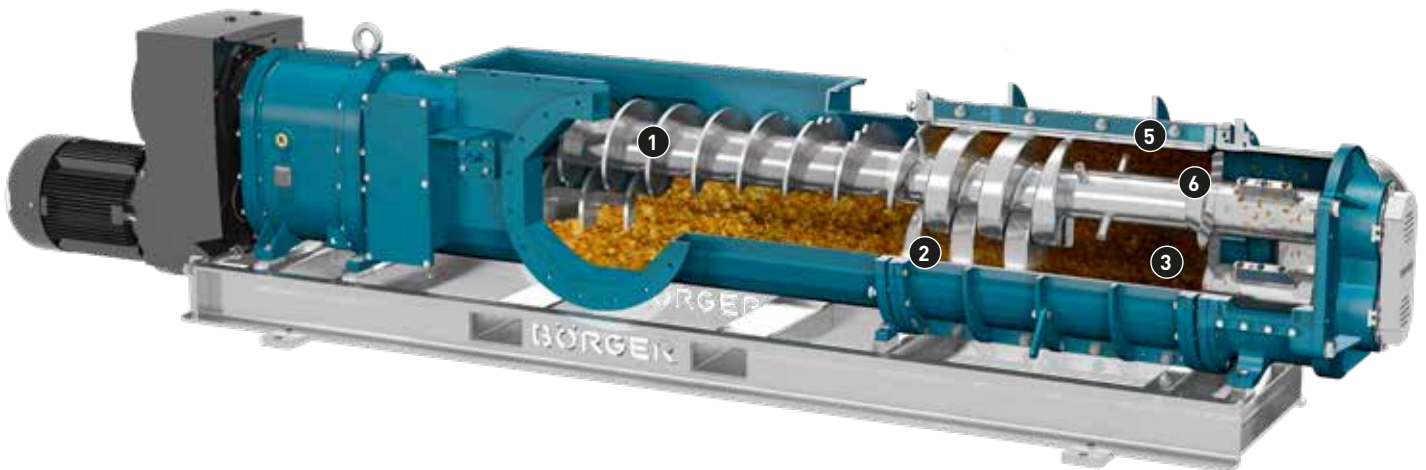

CONSTRUCTION AND FUNCTION

The biomass introduced is collected, broken up and partly macerated by means of the tearing tools of the augers (1). The biomass is fed to the compactor unit (2) by means of auger rotation. The double screw spindle unit (2) which seals in every position conveys the biomass into the press channel (3) by means of pressure. In the process, the mass is partly ground. An adjustable narrowing (5) is attached to the outlet side of the press channel. Combined with the screw spindle unit, strong compression is achieved in the press channel (3). The structure of the biomass is changed by the friction generated by the pressing procedure. Material disintegration can be increased if the optional tools (4) are installed in the press channel.

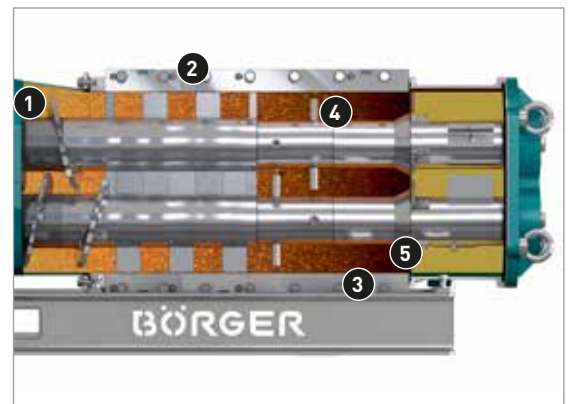



Powerfeed duo



Powerfeed



Powerfeed connect

POWERFEED AT A GLANCE

- + Dosing system for tanks of any number and of different heights
- + Enclosed system, so no odor emission or gas leakage
 - + Less power consumption
- + Less entrapped air, less buoyancy, less agitating

CASE STUDY: POWERFEED IN A BIOGAS PLANT

An operator of a biogas plant has been using a solids dosing feeder for feeding the biomass into the fermenter for several years. The operator was looking for an alternative feeding technology due to the extension of the biogas plant and the very high agitating effort. He opted for a Börger Powerfeed connect. The liquid feeding technology can be used for feeding tanks of any number. In addition, they were able to use the existing technology to a large extent.



in connect installation

BÖRGER®

EXCELLENCE – MADE TO LAST



Boerger, LLC
Chanhausen, MN 55317, USA
Phone +1 612 435 7300
america@boerger.com

Börger GmbH
Borken-Weseke, Germany
info@boerger.de

Börger Benelux
Ootmarsum, Netherlands
info@boerger-pumps.nl

Börger France S.A.R.L.
Wittersheim, France
info@boerger.fr

Boerger Polska Sp. z o.o.
Gliwice, Poland
info@boerger.pl

Börger UK Limited
Staffordshire, England
uk@boerger.com

000 Börger Pumps
Moscow, Russia
russia@boerger.com

Boerger Pumps (Shanghai) Co. Ltd.
Pudong, Shanghai, China
shanghai@boerger.com

Boerger Middle East FZCO
Dubai, United Arab Emirates
info@boerger.ae

Boerger Pumps Asia Pte Ltd
Singapore
asia@boerger.com

Boerger Pumps Asia Pte Ltd
Gurgaon, Haryana, India
india@boerger.com

www.boerger.com